



Halsey Taylor[®]
Satisfying Thirsts Since 1912

Heavy Duty, Freeze-Resistant Contour™ Barrier-Free

MODEL HDFEBPFR



This fountain is certified to
NSF/ANSI 61 and 372

GENERAL

Face-mounted 14 gauge heavy duty fountain, one-piece, non-corrosive series 300 stainless steel with brushed satin finish and one piece vandal resistant drain. Larger seamless drawn contour-formed basin with softly rounded corners and edges reduces splatter, insures proper drainage and prevents standing waste water. Slim Profile is designed to meet ADA specifications for children's use installations. Ideally suited for installation in public area. Model meets state and federal requirements as defined by the Americans with Disabilities Act.

FREEZE-RESISTANT VALVE SYSTEM

Freeze-resistant system features box that installs behind non-freezing wall for housing water connection from the stop to the strainer.

BUBBLER

Vandal-resistant bubbler is one-piece heavy-duty, with integral hood guard design to prevent contamination from other users, airborne deposits and tampering.

PUSHBUTTON ACTUATION MECHANISM

Self-closing, vandal-resistant pushbutton does not require grasping or twisting.

PANELS

Backpanel constructed of stainless steel, No. 300 series with satin finish. Solid 14 gauge heavy duty stainless steel underplate and vandal resistant pinned torx screws. 1/4" thick heavy duty stainless steel mounting backplate on fountain arm.

AUTOMATIC STREAM HEIGHT REGULATOR

Self-closing assembly is located inside unit to prevent tampering and can be adjusted from front pushbutton. Unit resists corrosion and liming. A constant stream height is automatically maintained under line pressures that vary from 20 to 105 psi (138 to 724 kPa).

INLET STRAINER

Easily cleaned in-line strainer screen traps particles of 140 microns or larger before they enter the waterway.

WATER INLET - 3/8" O.D. Tubing.

DRAIN OUTLET - 1-1/4" tube outlet for 1-1/4" slip joint connection.
Service stop not included.

SUGGESTED SPECIFICATIONS

Fountain shall include pushbutton on the front, contour-formed basin to eliminate splashing and standing water, and shall have rounded corners and edges with slim profile. Projector shall be vandal-resistant, one-piece, heavy-duty type with integral hood guard and anti-squirt feature. Fountain shall comply with ANSI 117:1 and ADA for visual and motion disabilities. The manufacturer shall certify the unit to meet the requirements of NSF/ANSI 61, and the Safe Drinking Water Act. Shall include freeze-resistant valve system.

Note: Continued product improvement makes specifications subject to change without notice. See Halsey Taylor website for most current spec sheet.

Fountain with Back Panel



Standard Finish is Stainless Steel

Optional Accessories (extra cost)

Water Filter

Each HDFEBPFR consists of 2 cartons of the following:

Fountain, Panel and Misc. Parts
Freeze-Resistant Valve System

Service stop not included.

Shipping weight: 60 lb (32 kg)

Job Name: _____
Model: _____ Qty. _____
Contact: _____
Approval Signature: _____
Notes: _____



HDFEBPFR

Heavy Duty, Freeze-Resistant Contour™ Barrier-Free FOUNTAIN WITH BACK PANEL

(CONTINUED)

MOUNTING INSTRUCTIONS

Refer to diagrams for rough-in of plumbing. Mount wall plate assembly to wall per the installation instructions. Hang fountain panel over the wall plate assembly. Attach fountains to wall plate assembly. Water service line and waste line are to be assembled as required. Final check for leaks and correct functions of fountain should be made. (For details see the installation instructions.)

Freeze resistant box must be installed on interior non-freezing wall.

A service supply stop must be installed at the fountain inlet line. Service supply stop not included.

CAUTION – Fountain must be securely bolted to wall.

OPERATING PRESSURES

Supply water - 105 psi maximum

Note: For wall support required locations see installation instructions provided with panel and fountains.

FRONT VIEW

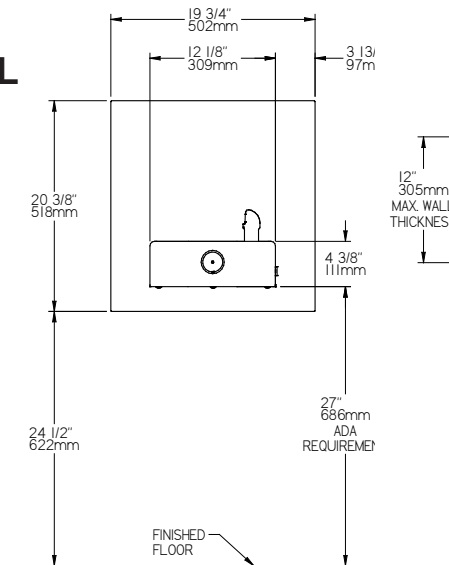

TOP VIEW

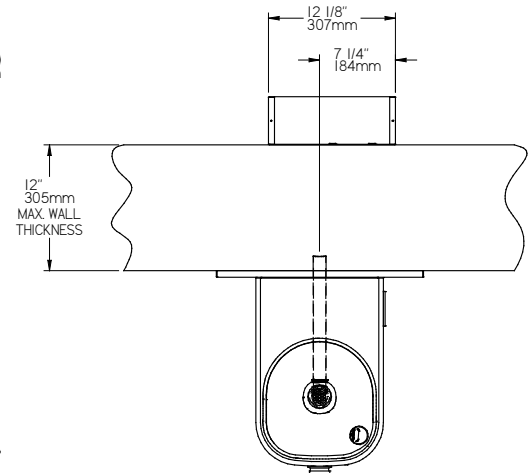

WALL VIEW

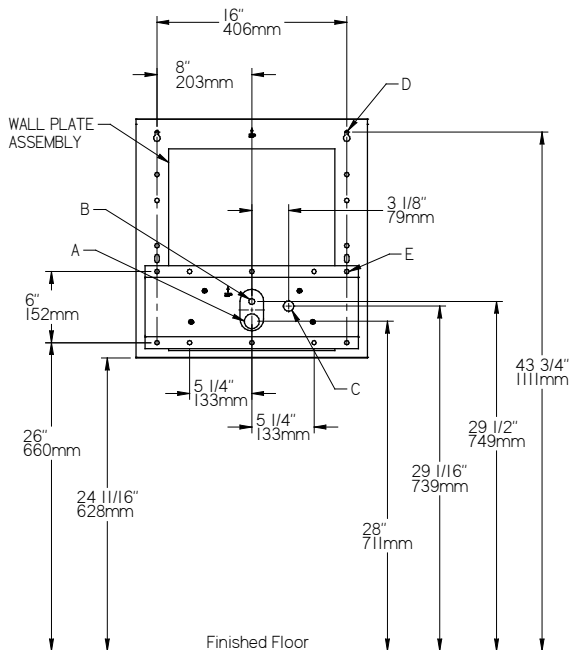

SIDE VIEW

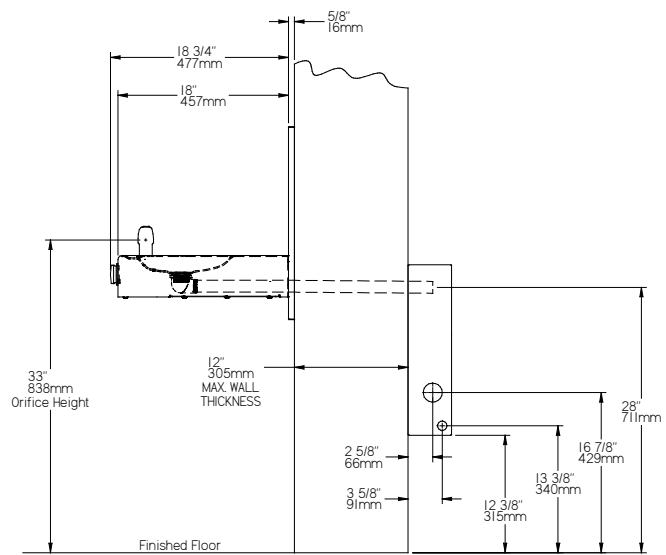

- A = 1-3/4" DIA. (44mm) HOLE FOR WASTE LINE
- B = 7/8" DIA. (22mm) HOLE FOR WATER SUPPLY
- C = 7/8" DIA. (22mm) HOLE FOR OPERATING CABLE
- D = 1/4" DIA. (6mm) HOLE FOR MOUNTING PLATE TO WALL
- E = 3/8" DIA. (6mm) HOLE FOR MOUNTING PLATE TO WALL

Halsey Taylor®